

All-reflective automated beam alignment device for ultrafast lasers

Matt Anderson^{a)} and Catherine Ward^{b)}

Department of Physics, San Diego State University, 5500 Campanile Dr., San Diego, California 92182-1233

(Received 16 December 2003; accepted 15 March 2004)

We present a novel device for automatically aligning laser beams using two quadrature photodiodes set immediately behind slightly transparent mirrors. The system utilizes feedback electronics and a LABVIEW program to automatically align an ultrafast laser quickly and accurately, even in the presence of gross thermal warping of the optical table. The design and implementation of this device is straightforward, making it an ideal research project for undergraduate students. © 2004 American

Association of Physics Teachers.

[DOI: 10.1119/1.1737398]

I. INTRODUCTION

Of critical importance to any laser system, but especially for ultrafast laser systems,¹ is proper optical alignment. These ultrashort pulses occupy a length scale of a few micrometers. Misalignment ultimately leads to temporal shifts of the pulses, which can drastically alter the results of ultrafast experiments such as pump-probe or four-wave mixing. A very clever alignment geometry using elliptical and parabolic mirrors was presented by MacFarlane,² who showed that femtosecond timing can be preserved in a passive setup. When dealing with laser alignment, researchers typically use pinholes to ensure the beam position. Two pinholes constitute an optical axis, and tedious realignment through these pinholes can occupy much of the researchers' time. A further frustrating aspect of alignment using pinholes is the offset between the pinholes and the steering mirror, thus necessitating an iterative approach of adjusting one mirror, then the second, and then going back to the first. Although fairly effective, this process takes time and is still subject to human interpretation as to the centering of the beam on the pinhole. The feedback control demonstration in Ref. 3 illustrated an automated approach to the alignment of beam pointing and stabilization of a Michelson interferometer. This type of project provides an excellent learning experience for an undergraduate student.

Many undergraduate institutions are now involved in research using ultrafast lasers. An ultrafast laser operates in the near-infrared region of the spectrum, which further complicates alignment because the human eye cannot see the beam. Invisible beams require special viewers or detecting cards to assist in the alignment process. These items add yet another level of difficulty for the two-handed scientist. Most ultrafast laser researchers rely on pinholes and infrared cameras or viewers to align beams, an often inaccurate and time-consuming route.

The main problem encountered with optical alignment is not the usually fast jitter of the optical beam, but rather slow-term drift. We have encountered this phenomenon when the optical table slowly warped as its temperature increased during the day due to the presence of refrigerated chillers underneath the table. We routinely measured displacements of several beam diameters by day's end. These misalignments often can go unnoticed for hours and can shift beams by a millimeter or more.

When dealing with ultrashort-pulsed lasers, an added com-

plication is minimizing the amount of glass through which the beam passes. For many beam-locking systems, a portion of the beam is split off with a beamsplitter and sent to a detector. The beam traveling through this portion of glass will suffer dispersion. An ideal system would be entirely reflective. Automatic alignment devices are commercially available.⁴ Most of them use piezo-electric transducers to shift a mirror's orientation. Although these devices are capable of correcting for rapid beam displacements (up to 100 Hz), they are in general not capable of adjusting for gross misalignments, because the travel of the transducers is limited. Furthermore, for systems that employ piezo stacks with limited angular travel, the footprint for these systems can be quite large.

In this paper, we discuss a new beam alignment tool that solves these problems, is less expensive than commercial systems, and is easy to build.⁵ Our device, although it cannot correct for extremely fast jitter, is able to realign beams that are grossly misaligned because the adjustment range of the positioners is substantially larger, up to 12 millimeters. This amount of travel also allows the footprint to be rather small. Our beam alignment guide for laser experiments (BAGLE) alleviates the hassles of dealing with pinholes and ensures optimum alignment. It is an all-reflective, low-dispersion, beam-positioning device that uses three mirrors, two quadrature detectors, and four motorized positioners. The system can easily be operated with a variety of lasers, including HeNe, by picking appropriate mirrors. Thus, it is an ideal project for undergraduates and allows them to combine aspects of beam alignment, electronics, and computer feedback in one simple system.

II. BAGLE OPERATION

We now explain the fundamental operation of this device. The method may be understood by the following fact that any two spatial points determine an optical axis. In this device, our two spatial points consist of the crosshairs of two quadrature detectors (each consisting of four silicon photodiodes sandwiched together). The quadrature detectors will be mounted directly behind ultrafast laser mirrors, which reflect 99.7% of the incoming light and transmit the other 0.3%. The schematic for the device is given in Fig. 1 and consists of the following: two motorized mirror mounts, one stationary mirror mount, three ultrafast mirrors, two quadrature detectors, and a computer. The detector readings indicate

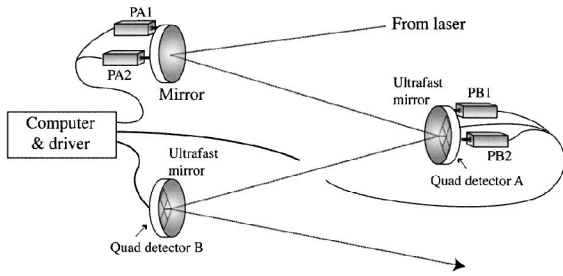

Fig. 1. BAGLE components.

in which direction the beam is misaligned, and a feedback circuit controls the positioners. As seen in the diagram, detector A feeds back to positioners PA1 and PA2, and detector B feeds back to positioners PB1 and PB2. The added benefit of this scheme is twofold: (1) A repositioning of positioners PB1 or PB2 does not require any adjustment to PA1 or PA2, and (2) the unwanted translation of the beam is essentially zero because the detector lies so close to the adjustment plane.

BAGLE automates alignment procedures and provides a quick means for analyzing beam-pointing stability. The novelty of this device lies in the implementation of the quadrature detectors: They are embedded directly behind the ultrafast mirrors which allows for alignment correction without beam translation. This alignment feature is impossible to obtain with pinholes and mirrors, because the pinhole is necessarily detached from the steering device, thus producing unwanted translation of the beam.

A close-up of the mirror and detector is shown in Fig. 2. The detector is positioned immediately behind the ultrafast mirror, offset slightly such that gross adjustments of the mirror tilt will not hit the detector surface. The detectors were mounted to a rod assembly with hot glue.

The prototype is shown in Fig. 3. We found that a 20 cm separation between the mirrors is a good working distance. This separation allows for large misalignments, yet retains suitable precision.

III. FEEDBACK CIRCUIT AND CONTROL

As shown in Fig. 2, the quadrature photodiode array is aligned at 45° relative to the table. In this way, there are two (horizontal) photodiodes that identify the x -position of the beam, and two (vertical) photodiodes that locate the y -position of the beam. The idea behind the electronic feedback circuit is to compare the two signals from these corresponding photodiodes and act accordingly. The outputs from these detectors are passed through a shaping circuit that amplifies the voltage from the photodiode, and the signals are then recorded in the computer. A computer program analyzes the signals from the photodiodes and tells the corresponding positioner to advance or retreat. This procedure can be done in one of two ways.

The first is to measure all eight photodiodes independently, then to subtract their signals in the computer. This approach, of course, requires eight a/d inputs to the computer. The leads from the quadrature detector were soldered to a ribbon cable that went to a shaping electronic circuit, and then to the a/d ports of the ESP6000 board. We found it necessary to build a small amplifier circuit to amplify the photodetector signals before sampling them with the board.

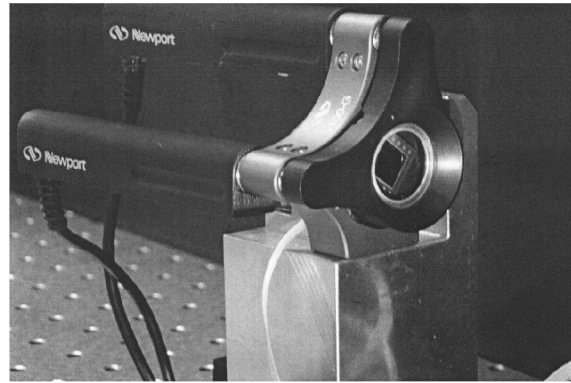

Fig. 2. Ultrafast mirror mounted with motorized positioners in front of the quadrature detector.

This procedure is fairly straightforward, but if you need assistance, a good source is Ref. 6. One benefit of this procedure is the ability to measure the optical power by simply adding the signals from the four photodiodes on one quadrature detector. This feature also permits the user to normalize the feedback signal by the total laser power, improving the stability in the presence of power fluctuations.

The second approach used a differencing circuit to subtract corresponding photodiode signals and then send these four voltages to the computer. The circuit for this implementation is shown in Fig. 4. The circuit is powered by a single +5 V supply, which mandates that we create a virtual ground with two 100 Ω series resistors as shown in Fig. 4. All signals are then referenced to this 2.5 V virtual ground. The schematic on the left side of Fig. 4 shows the two photodiodes feeding into individual comparators, which amplify the detector signals. They are then subtracted in a difference circuit and multiply inverted and amplified via several more op amps. The final op amp allows the user to set an arbitrary dc offset to the output signal. The output at pin A represents the misalignment signal of the beam at the position of the detector along a particular direction (horizontal or vertical).

This circuit is, by no means, optimum; we merely found it to give good performance with our laser. Several simplifications could be implemented. For instance, one of the inverting amplifiers was originally designed to act as an integrator. This design caused systematic problems, so it was converted back to a unity gain inverting amplifier. Obviously, circuit

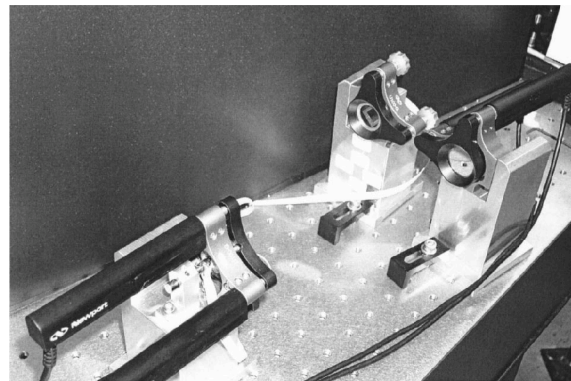

Fig. 3. The BAGLE prototype.

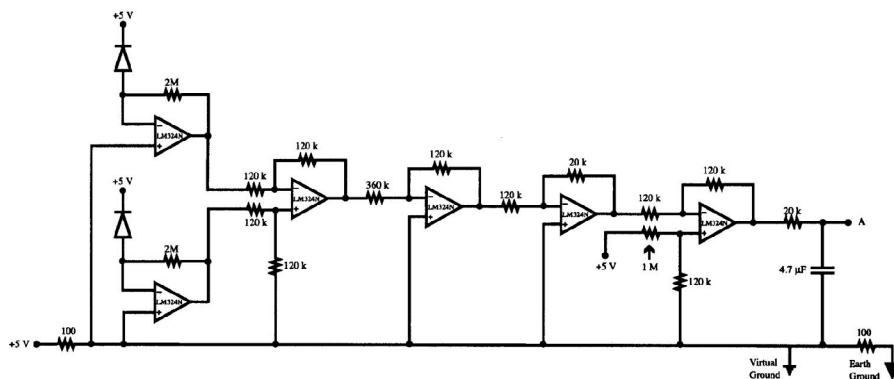

Fig. 4. Electronic feedback circuit. Each photodiode shown is one quadrant of the (four diode) quadrature detector. The op amps used were LM324N.

needs will change depending on specific detectors, power levels, etc., and modifications of this circuit are welcome.

The difference signals were fed to the computer with an a/d board. They were read by a LABVIEW program that analyzed the signals and decided on the adjustment. The LABVIEW program controlled four independent motorized translators that move to minimize the difference signals. The direction and speed of the motors was variable, which was key to optimizing the convergence toward proper alignment. It was discovered rather quickly that overshoot caused a big problem; the mirror would overshoot the correct position and begin to oscillate. We solved this overshoot by including a damping function to slow down the mirror as it approached the correct position. After trying various functional forms for this damping function, we finally settled on the hyperbolic sine function. This form has the preferred behavior of allowing high velocities when gross adjustments were needed, yet quickly slowed the motor as it approached target alignment.

IV. EXPERIMENTAL RESULTS

The BAGLE system has the following performance characteristics. With a mirror separation of 20 cm, the maximum angular speed of response is 32 mrad/s and a lateral translation speed of 6.4 mm/s. The minimum beam displacement is 5 μm and the angular resolution is 30 μrad . The maximum adjustment range is 25 mm lateral beam displacement. The maximum angular travel for each individual mirror is 52°. Finally, the overall optical throughput of the device is greater than 97%.

We tested the system and found that it performed admirably under a variety of conditions, repeatedly aligning itself within several seconds for even gross misalignment. One measure of its performance is its ability to quickly realign itself on two pinholes downstream from BAGLE. To illustrate this, we first ran BAGLE and aligned two pinholes downstream. We then turned BAGLE off and misaligned the beam with a mirror upstream from BAGLE. The misalignment on the two pinholes is shown in Fig. 5. We then ran BAGLE, and within four seconds it realigned the beam on its two crosshairs, which realigned the beam on the two pinholes. The alignment is shown in Fig. 6.

To quantify its behavior, we performed two experiments. The first was to compare BAGLE's performance to that of an undergraduate. The student was instructed to align the laser using a pinhole and an IR viewer. We then measured the power through the pinhole. An instructor then altered the

alignment of a different mirror, and the student was instructed to again align the beam through the pinhole. The power through the pinhole was measured with a detector, and we repeated this process several times. We then performed the experiment again, with BAGLE taking the place of the undergraduate. The instructor would misalign the beam, and BAGLE would realign it. The results are shown in Fig. 7. The standard deviation for the student's performance was $\sigma_{\text{student}}=4.8 \text{ mW}$, for BAGLE it was $\sigma_{\text{BAGLE}}=0.2 \text{ mW}$ (which was the same order as the fluctuations of the laser power alone).

The second experiment was designed to test the performance of BAGLE under slowly varying thermal conditions. We used a small 2500 W space heater to slowly heat the optical table. The heater was placed directly on the floor beneath the optical table. The beam height was recorded and the results are shown in Fig. 8. The beam is seen to shift by 0.82 mm over the course of 15 min. This amount of displacement was measured across the full length of an 8-ft.-long optical table. The experiment was repeated with the feedback on, and much better results were obtained. The BAGLE device consistently realigned the position, keeping it at the de-

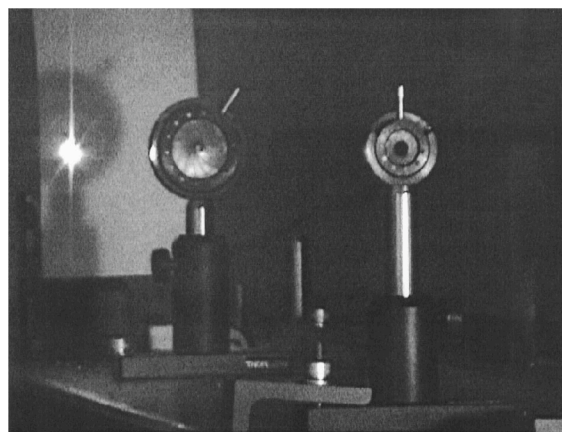

Fig. 5. Misaligned laser. The laser beam is propagating from right to left in the picture. The beam is missing the first pinhole entirely, just grazing the second pinhole, and hitting the white screen (the bright spot on the left side of the picture).

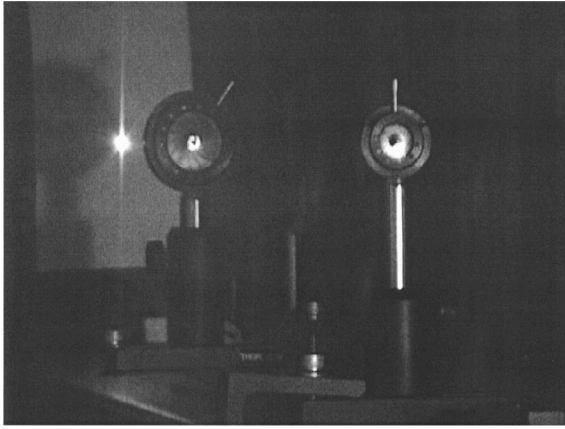

Fig. 6. Aligned laser. This image was recorded four seconds after BAGLE was turned on. The laser beam now passes through both pinholes and hits the screen.

sired height. This sort of device could greatly benefit regenerative amplifiers for which the “seed” alignment is critical to proper amplification.

V. CONCLUSIONS

We have developed a novel beam alignment tool for laser laboratories. We have demonstrated its performance with an ultrafast Ti:sapphire laser, but it easily could be adapted to other laser sources. We have found the system to be very robust, precise, and quick. It is widely adaptable and very user friendly (thanks in large part to LABVIEW). Furthermore, the design has minimal walkoff, superior resolution, and extremely high optical throughput with no dispersive elements. We demonstrated that the system can align quickly and accurately, and maintain beam pointing over long time intervals even in the presence of thermal expansion of the optical table.

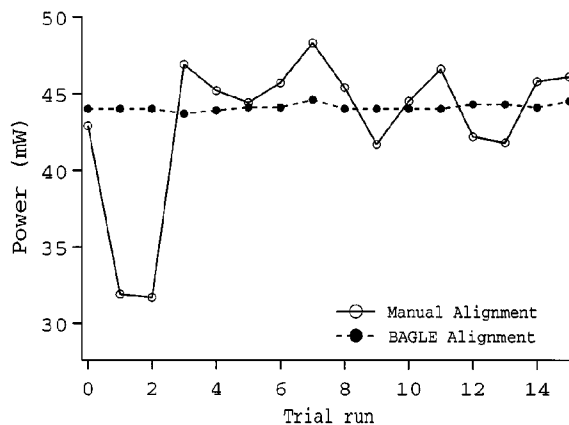

Fig. 7. Measuring alignment performance manually (open circles) and with BAGLE (solid circles).

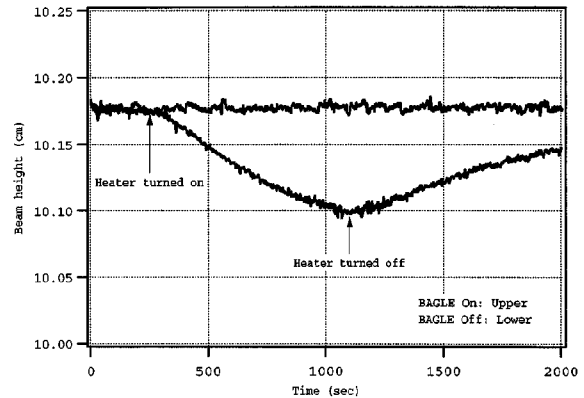

Fig. 8. Measured beam height as a function of time with a space heater set directly underneath the optical table.

ACKNOWLEDGMENTS

This work was supported by an Undergraduate Research Award from Sigma Pi Sigma, and a generous donation from Newport Corporation.

APPENDIX: PARTS LIST

- 4 Motorized positioners, Newport CMA-12CCCL \$750 each
- 1 Positioner driver, Newport ESP6000DCIB-OPT, \$1955
- 4 Positioner driver axis option, Newport ESP6000DCIB Axis Option 08, \$460 each
- 2 Ultima mounts (no actuators), Newport U100-G, \$129 each
- 1 Ultima mount (with actuators), Newport U100-G21, \$152
- 3 Ultrafast mirror, Newport #10B20UF.25, \$298 each
- 2 Hamamatsu quadrature photodetectors, S5982, \$50 each

^{a)}Electronic mail: matt@sciences.sdsu.edu

^{b)}Present address: Quantum Magnetics Inc., 15175 Innovation Drive, San Diego, California 92128.

¹H. Kapteyn and M. Murnane, “Ultrashort light pulses: life in the fast lane,” *Phys. World* **12** (1), 31–35 (1999).

²D. L. MacFarlane, “Laser beam alignment devices for ultrashort pulses,” *Rev. Sci. Instrum.* **62** (8), 1899–1903 (1991).

³K. A. Jensen, R. L. Larson, S. D. Bergeson, and E. F. McCormack, “Exploring feedback control using experiments in optics” (2001), arxiv.org/abs/physics/0106091

⁴Newport, (<http://www.newport.com/store/>). Search for laser beam stabilization modules.

⁵This project was presented by Ms. Ward as part of the *Symposium on Undergraduate Research at the Optical Society of America Annual Meeting*, Long Beach 2001. If you are interested in building a BAGLE and need some tips, a copy of our LabView program, or would like to see QuickTime movies of BAGLE in action, contact Dr. Matt Anderson at (matt@sciences.sdsu.edu) or visit (<http://www-rohan.sdsu.edu/~sps/ultrafast/>)

⁶Paul Horowitz and Winfield Hill, *The Art of Electronics* (Cambridge U.P., Cambridge, 1989).